

FLW FLEXP-WATER

IN-LINE PROCESSORS



MAIN FEATURES

In-line processor for flexo-water plates



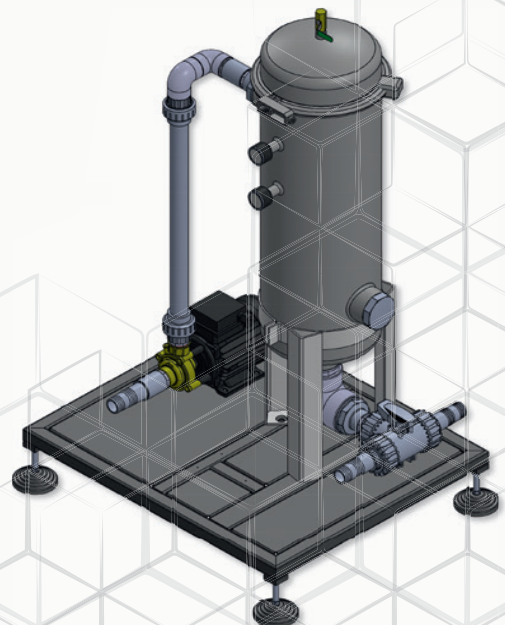

- Touch screen PLC controller
- Washout and pre-dryer section
- Washout of the plate via two orbital brushes
- Sponge roller for removal of the water excess before the pre-dryer
- Cleaning through a cylindrical brush
- Processing water separated from the cleaning water
- Detergent dosing pump
- Compressed air and water supply needed

Optional

- Exposure section, dryer, anti-tack and post-exposure compartment
- Filter recycling unit



TECHNICAL DATA

	560	760	920	1070	
	520x760 mm 20/29"	760x1100 mm 29x43"	920x1200 mm 36x47"	1070x1530 mm 42x60"	 Maximum Plate Size
	128x331x110	149x331x110	158x475x127	170x502x127	 Overall Dimensions LxWxH cm
with tunnel	128x495x110	149x495x110	with tunnel only		
	380	420	900	1040	 Weight kgs
with tunnel	520	640			
	230V 60Hz 3PH+GND 400V 50Hz 3PH+N+GND				 Power Supply
	7,5 kW	13 kW	13 kW	13 kW	
	45	80	110	110	Tank Capacity lt

